

CHAPTER 1 GETTING STARTED

This chapter describes the procedures from unpacking the EM-200, to powering it on. The following topics are described.

- Unpacking the machine on page 1
- Checking the package contents on page 2
- Identifying components on page 3
- Installing the battery pack on page 8
- Charging the battery pack on page 9
- “Powering on” on page 10

Unpacking the machine

The machine and cable accessories are packed in a cardboard carton with foam padding for protection during shipping.

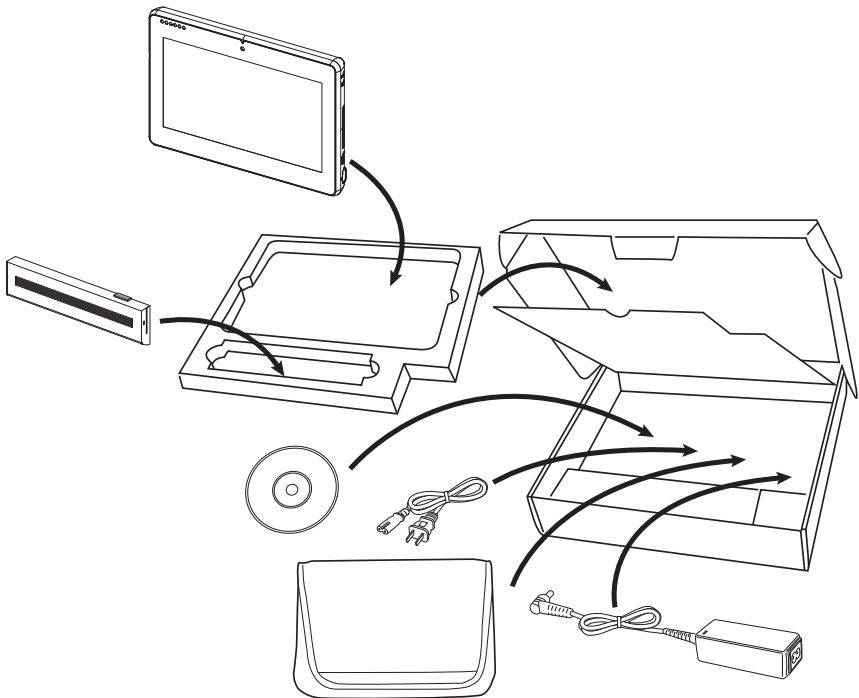
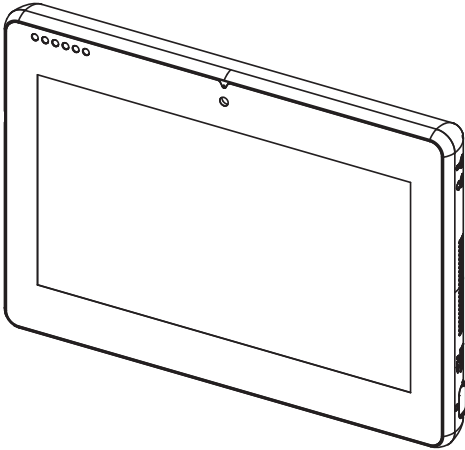

Figure 1.1 Unpacking the machine

Carefully unpack the machine and keep the packing materials. If you need to ship it in the future, repack it as shown in Figure 1.1.

Checking the package contents

After you unpack the device, check that the following items are included.



EM-200

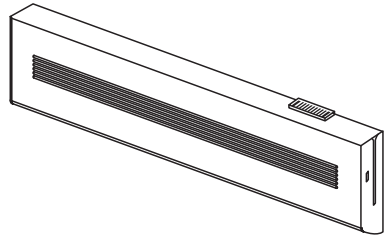

Battery

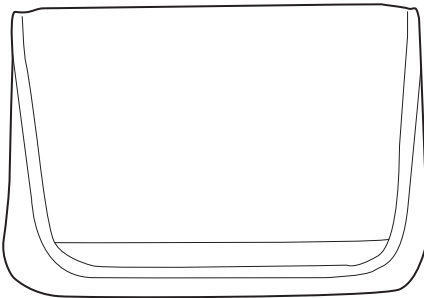

Protection pack

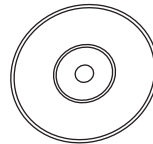

Driver CD with drivers and the user manual PDF file.

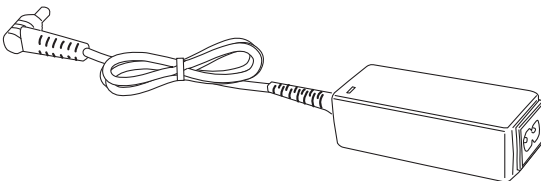

AC adapter

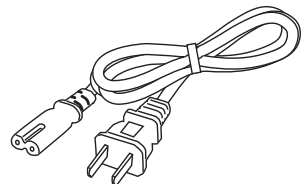

Power cord

If any item is missing or appears damaged, contact your dealer immediately.

Identifying components

This section describes the parts and connectors on the machine.

Front view

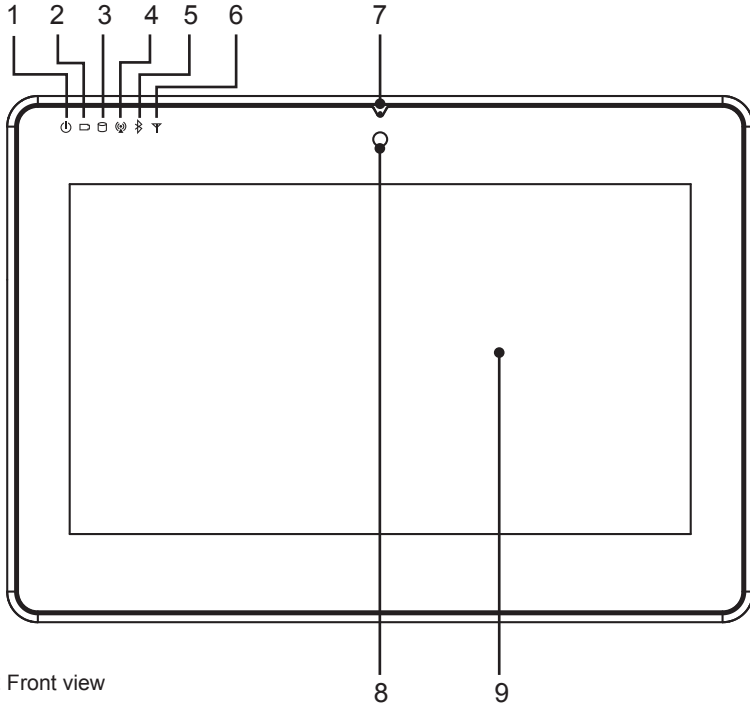

Figure 1.2 Front view

Component	Description
1	Power indicator
2	Battery charging indicator
3	HDD status indicator
4	WiFi On/ Off indicator
5	Bluetooth On/ Off indicator
6	3.5G LAN On/Off indicator (optional)
7	Built-in Microphone
8	Camera (optional)
9	10.1-inch touch panel

Left view

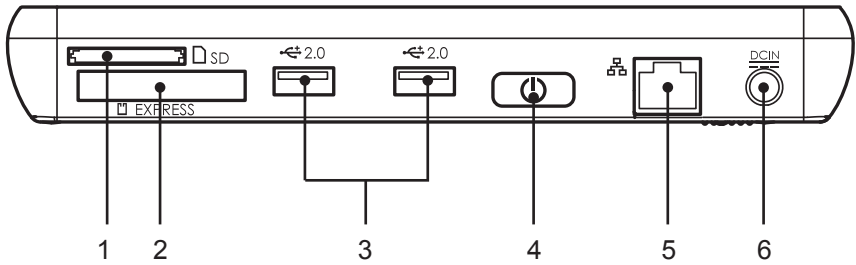

Figure 1.3 Left view

Component	Description
1	5-in-1 media card slot
2	Express card 34 slot
3	USB port
4	Power button
5	RJ45 LAN jack
6	DC IN

Right view

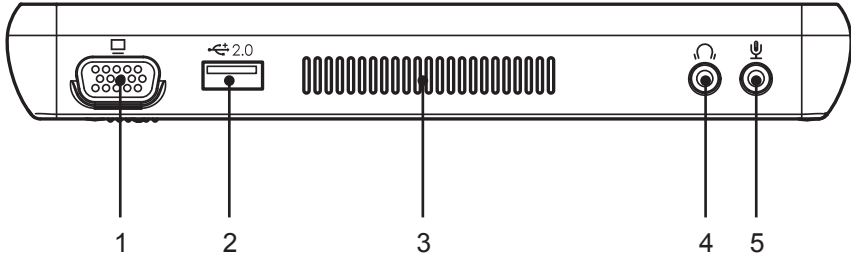

Figure 1.4 Right view

Component	Description
1	VGA port
2	USB port
3	Ventilation hole
4	Headphone jack
5	Microphone jack

Rear view

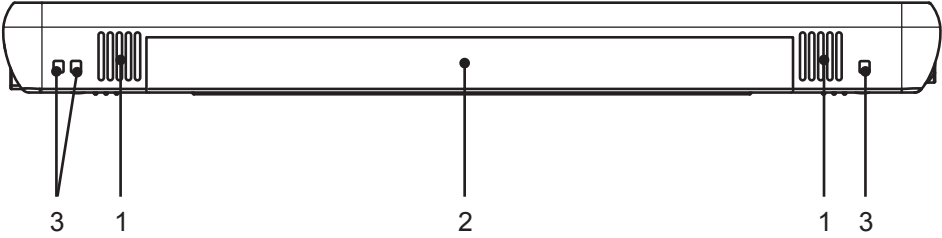



Figure 1.5 Rear view

Component	Description
1	Speaker
2	Battery pack
3	Charger pin: connect to a cradle for charging the battery.



Do not short-circuit the 3 charger pins. A short-circuit may cause damage to the machine and present risks for electric shock or fire.

IMPORTANT

Bottom view

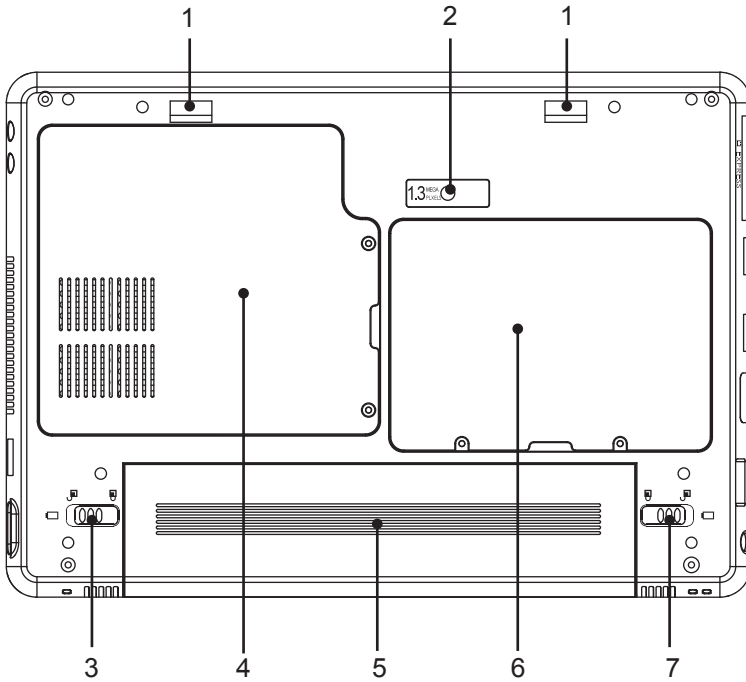
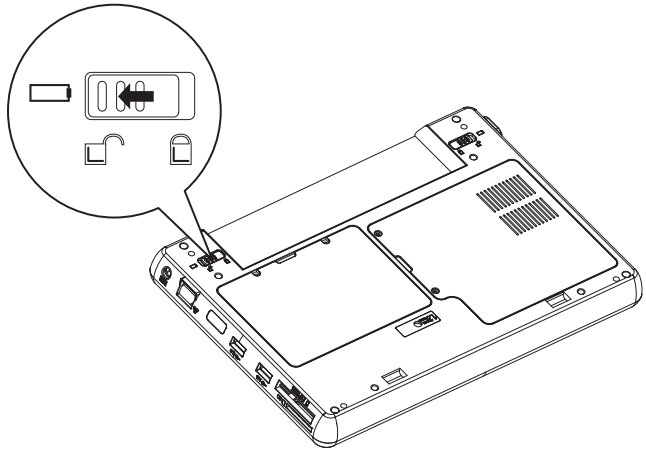

Figure 1.6 Bottom view

Component	Description
1	Mounting hole
2	Camera (optional)
3	Battery lock switch
4	Memory, WiFi module, Bluetooth module and 3.5G LAN module (optional) slots
5	Battery pack
6	HDD compartment
7	Battery release latch

Installing the battery pack

1. Overturn the EM200 so that the bottom is facing up toward you, as shown in the right. Slide the battery release latch to the unlock position.



2. Align EM200 battery compartment pins to the battery connector. Slightly slide and press the battery pack into the compartment until the battery lock switch is bounced back.

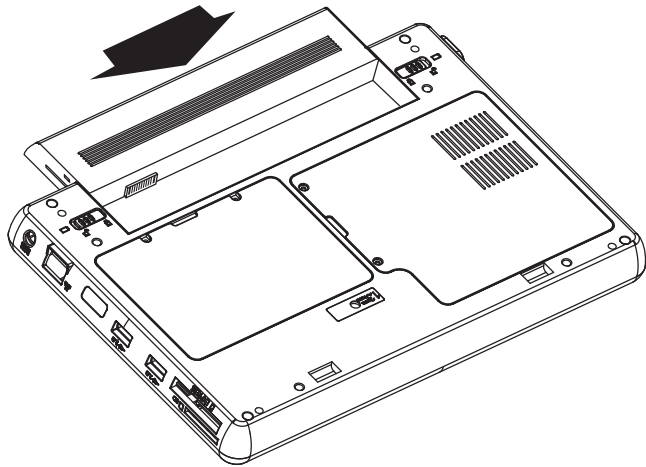

3. As shown in the right, slide the battery release latch to the lock position.

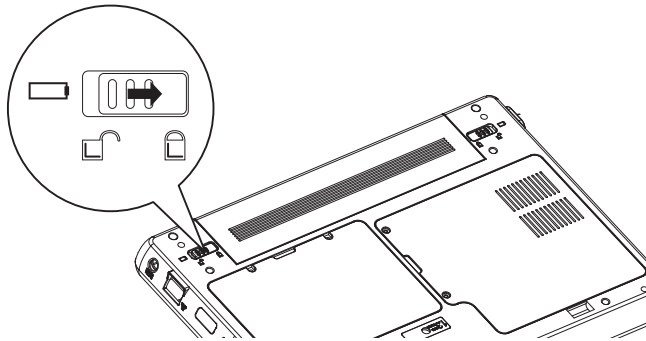

Charging the battery pack

Plug the AC adapter power cord into an electrical outlet, then connect the DC plug of the adapter cable to the EM-200. It takes approximately 2–4 hours to fully charge the battery for the first time. Subsequent charges might take longer.

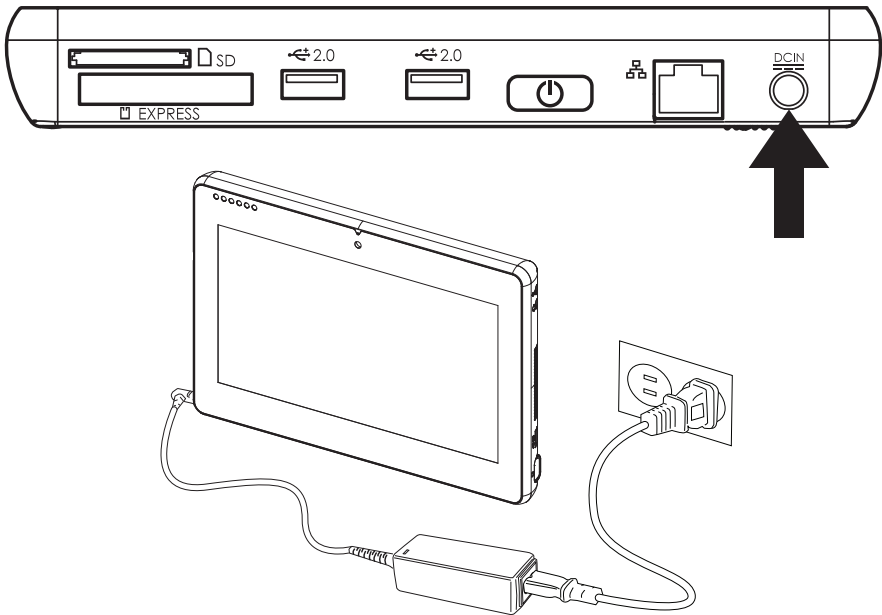

NOTE

Charge the battery within a temperature range 0°C to 45°C.



IMPORTANT

To protect and prolong the life of the battery, do not charge it for 24 hours or longer at a time.



IMPORTANT

Please make sure to perform 3 complete full charge and discharge cycles to get optimal battery capacity. Failure to comply will result in shorter battery lifespan.



IMPORTANT

If battery is not used, please store in dry area within a temperature range of -10°C ~ 20°C. It is necessary to charge the battery once every 3 months to avoid battery degradation. Battery may become unusable if the above is not respected.

Powering on

The power button located on the left side of the EM200, press the power button the turn it on.

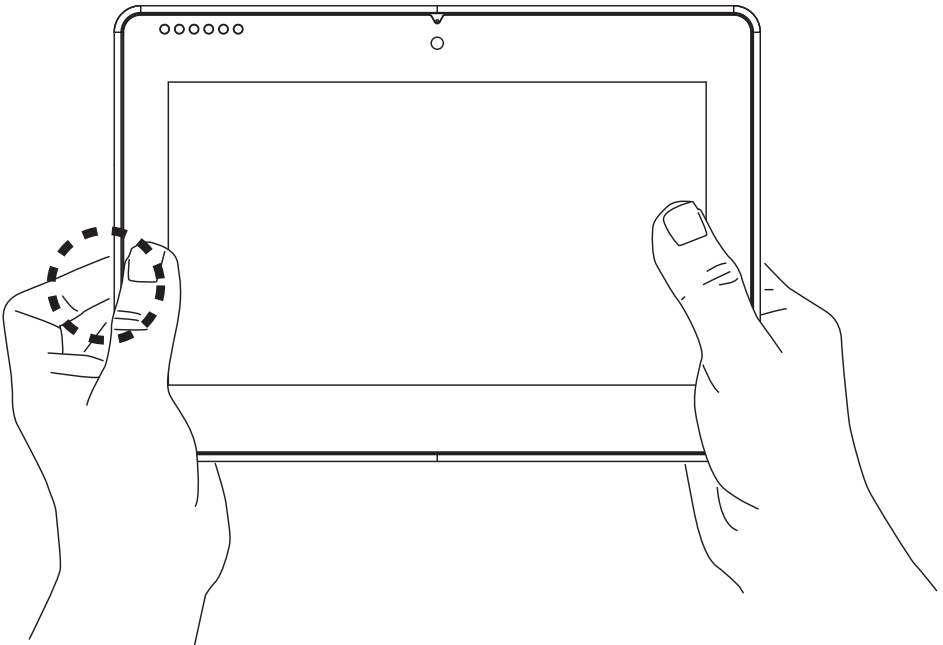
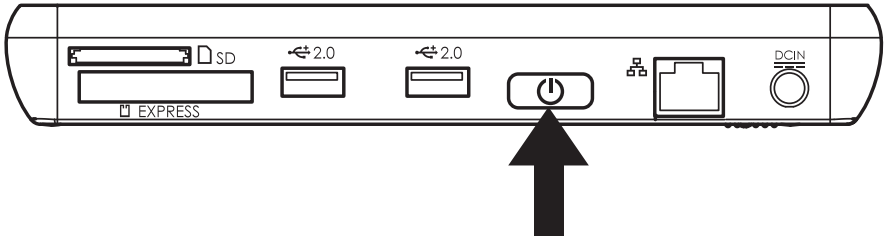

NOTE

To force power off , long press the power button for 4~5 seconds.